

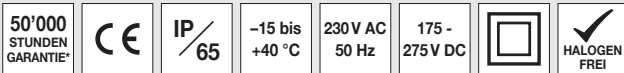

SIMPLEMENT 2

230V

Montageanleitung Installation Manual

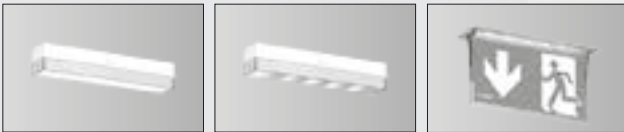

1. Masszeichnungen / Dimensional drawing [mm]

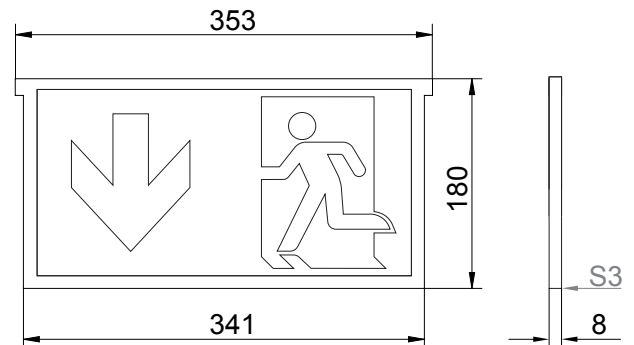
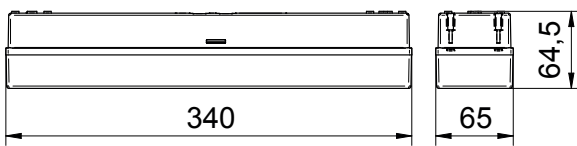

2. Sicherheitshinweise / Safety instructions

- Die Leuchte ist vor Montage auf Beschädigungen und Auffälligkeiten zu kontrollieren.
Check the luminaire for damage and abnormalities before installation.
- Als Ersatz dürfen nur Originalteile von ALMAT verwendet werden.
Original parts of ALMAT are only allowed to be used as replacement.
- Bei Arbeiten an der Leuchte ist das Netz abzuschalten.
During work on the luminaire first switch off the electrical network.
- Halten Sie die für das Errichten und Betreiben von elektrischen Betriebsmitteln geltenden Sicherheitsvorschriften, das Gerätesicherheitsgesetz sowie die allgemein anerkannten Regeln der Technik ein. *For installation and operation of electrical equipment, comply with the applicable safety regulations, the equipment safety act as well as the general rules of technique.*
- Halten Sie bei Inspektion, Wartung und Instandhaltung die Bestimmungen für elektrische Betriebsmittel ein.
Comply with the regulations of electrical equipment during inspection and maintenance.
- Beachten Sie bei allen Arbeiten an der Leuchte die nationalen Sicherheits- und Unfallverhütungsvorschriften sowie die Sicherheitshinweise in der Betriebsanleitung, die mit \triangle gekennzeichnet sind. *During all workings at the luminaires consider the national safety- and accident prevention regulations as well as the safety instructions of the instruction manual marked with \triangle .*
- Tragen Sie bei Montagetätigkeiten die notwendige Schutzbekleidung/-ausrüstung.
During installation operations wear necessary protective clothing/-equipment.
- Die Leuchte darf nicht auf vibrierende Oberflächen montiert werden.
The Luminaire must not be mounted on vibrating surfaces.
- Die Leuchte ist zur Verwendung als Not- und Sicherheitsbeleuchtung in Gebäuden vorgesehen.
The luminaire is intended for use as emergency lighting in buildings.

3. Montageanweisung / Installation instruction



Attention

Diese Leuchte ist gemäss EN 60598-2-22 nur für die Montage in Anlagen bestimmt, in denen die Steckverbindung vor unbefugtem Trennen geschützt ist.
The luminaire is referred to EN 60598-2-22 specified for the installation in systems, where the electrical connection is protected against unauthorized disconnection.



Attention

Montage, Inbetriebnahme und Wartung darf nur durch die entsprechende Fachkraft durchgeführt werden!
Installation, initiation and maintenance are only allowed by a qualified person.



4. Installation / Installation

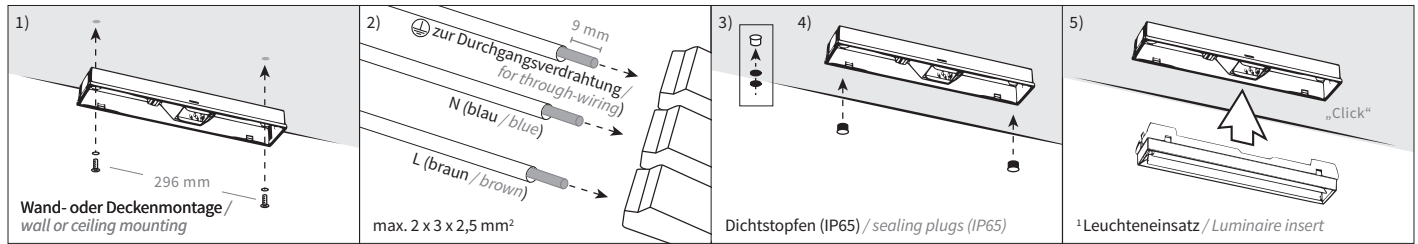

¹ Leuchteneinsätze / Luminaire inserts

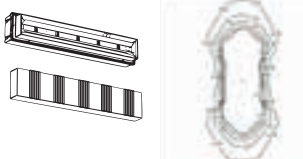
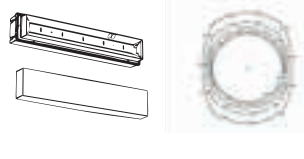
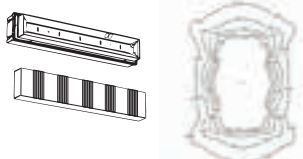
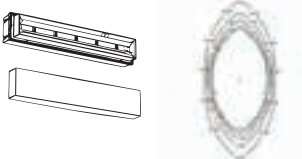
 <p>SIMPLEMENT 2 SL</p> <p>Nennleistung Leuchtmittel: 3,4W <i>Nominal capacity illuminant</i></p> <p>Max. Gesamtgewicht der Leuchte: 0,47 kg <i>Maximum of luminaire weight</i></p>	 <p>SIMPLEMENT 2 AP</p> <p>Nennleistung Leuchtmittel: 3,4W <i>Nominal capacity illuminant</i></p> <p>Max. Gesamtgewicht der Leuchte: 0,47 kg <i>Maximum of luminaire weight</i></p>	 <p>SIMPLEMENT 2 AS</p> <p>Nennleistung Leuchtmittel: 3,4W <i>Nominal capacity illuminant</i></p> <p>Max. Gesamtgewicht der Leuchte: 0,47 kg <i>Maximum of luminaire weight</i></p>	 <p>SIMPLEMENT 2 TS</p> <p>Nennleistung Leuchtmittel: 3,4W <i>Nominal capacity illuminant</i></p> <p>Max. Gesamtgewicht der Leuchte: 0,47 kg <i>Maximum of luminaire weight</i></p>
---	---	--	---

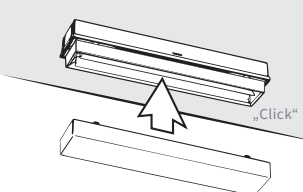
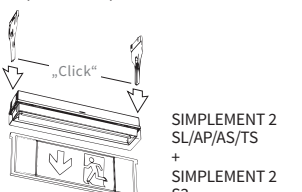
<p>6) Adressierung / Addressing</p>  <p>0 + 0 = Überwachung aus <i>monitoring off</i> 0 + 1 = 1 0 + 2 = 2 1 + 1 = 11 2 + 0 = 20 Maximum <i>maximum</i></p>	<p>Attention</p> <p>Die Adressierung wird bei Leuchten ohne Überwachung nicht benötigt! <i>No addressing required at un-monitored luminaires!</i></p> <p>Attention</p> <p>Die Leuchte darf ausschliesslich mit einem ALMAT-Vorschaltgerät betrieben werden! <i>The operation of the luminaire is only allowed with a ALMAT - supply unit!</i></p>	<p>7) Haube / Cover</p>  <p>„Click“</p>	<p>8) Optional / Optional</p>  <p>„Click“</p> <p>SIMPLEMENT 2 SL/AP/AS/TS + SIMPLEMENT 2 S3</p>
---	---	---	--

Massangaben in mm / Dimensions in mm

*gemäss ALMAT-Garantie- und Gewährleistungsbedingungen /

*according to the ALMAT-guarantee- and warranty conditions